

Air Intake/Filtration

Ref #	Part	Description	Qty
1	25 048 11-S	CLEANER, AIR-CANISTER (INCLUDES 2-8)	1
2	25 096 06-S	COVER ASSMBLY,AIR CLEANER (INCLUDES 3, 4)	1
3	24 462 07-S	VALVE, DUST EJECTOR	1
4	25 154 05-S	CLIP	2
5	25 083 01-S	ELEMENT, AIR FILTER - PRIMARY	1
6	25 083 04-S	ELEMENT, AIR FILTER - SAFETY	1
7	25 081 01-S	HOUSING, HEAVY DUTY A/C	1
8	25 139 20-S	PLUG, PIPE	1
9	24 326 71-S	HOSE, AIR CLEANER	1
10	25 237 21-S	CLAMP, HOSE	2
11	M-651016-S	SCREW, FLG M6X1.0X16	4
12	24 029 61-S	ADAPTER, REMOTE AIR CLEANER	1
13	24 041 06-S	GASKET, AIR CLEANER BASE	1
14	M-651025-S	SCREW, FLG M6X1.0X25 - USE 25 086 124-S	2
15	66 081 14-S	HOUSING, THERMOSTAT	1
16	66 453 01-S	THERMOSTAT	1
17	66 164 23-S	KIT, INTAKE MANIFOLD (INCLUDES 13, 18-20, 24 041 38-S, 24 041 34-S, 24 041 14-S)	1
18	66 041 01-S	GASKET, THERMOSTAT	1
19	66 041 05-S	GASKET, INTAKE MANIFOLD	2
20	66 155 02-S	CONNECTOR, HOSE (AFTER S/N 361280001)	1
21	45 155 01-S	CONNECTOR (BEFORE S/N 3612800011)	1
22	M-651050-S	SCREW, FLG M6X1.0X50	4
23	M-651090-S	SCREW, FLG M6X1.0X90	2
24	66 418 02-S	SENSOR ASSY, TEMPERATURE (INCLUDES 25, 26)	1
25	25 158 18-S	BUSHING, REDUCING	1
26	25 452 22-S	TERMINAL, EYELET/SPADE	1
27	66 126 73-S	BRACKET, AIR CLEANER BASE	1
28	M-647060-S	NUT, LOCK M6X1.0	2
29	X-25-53-S	WASHER, FLAT 1/4"	4
30	66 126 51-S	BRACKET, AIR CLEANER	1
	24 041 38-S	GASKET, AIR CLEANER ADAPTER NOT ILLUSTRATED	1
	24 041 34-S	GASKET, ADAPTER NOT ILLUSTRATED	1
	24 041 14-S	GASKET, AIR CLEANER BASE NOT ILLUSTRATED	1

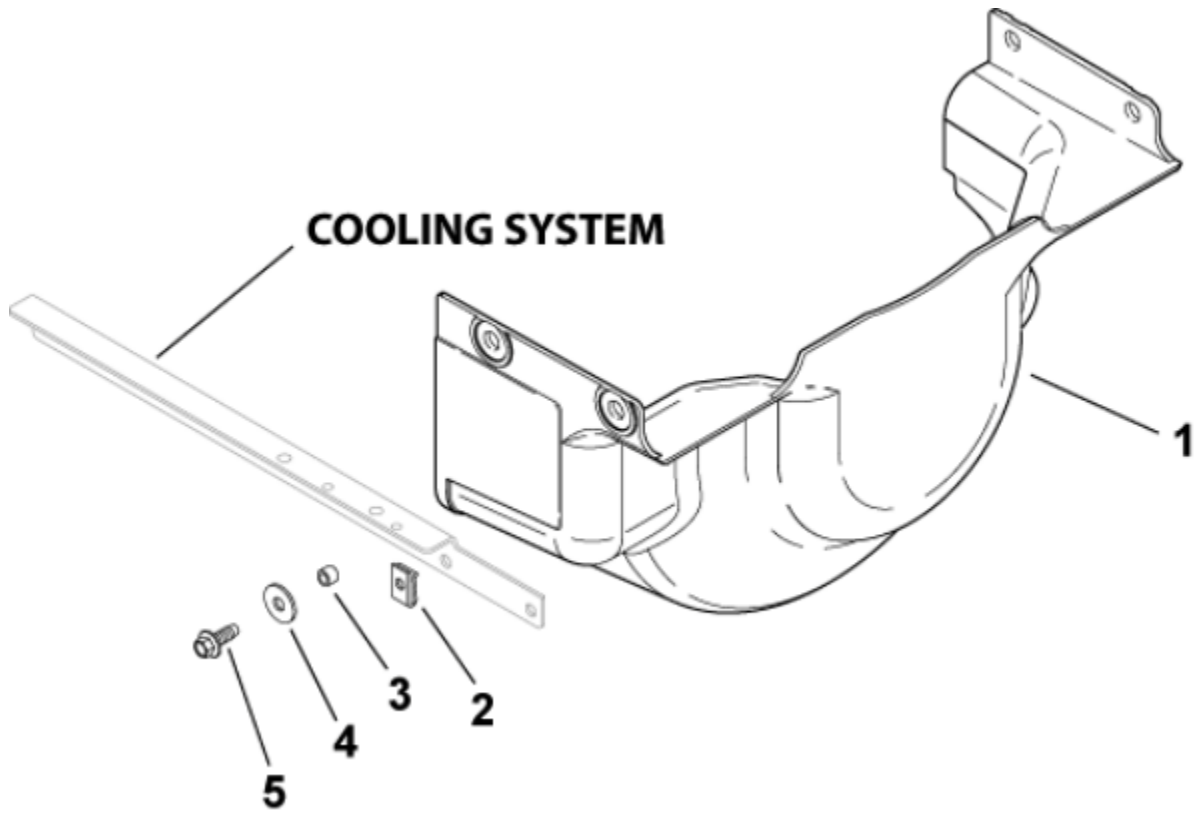

Blower Housing & Baffles

Ref #	Part	Description	Qty
1	66 096 09-S	COVER, ENGINE FLYWHEEL	1
2	66 154 05-S	CLIP	4
3	25 431 01-S	SPACER	4
4	X-25-52-S	WASHER, FLAT 1/4"	4
5	24 086 42-S	SCREW, FLG THD FRM M6X1.0X16	2

Cooling System

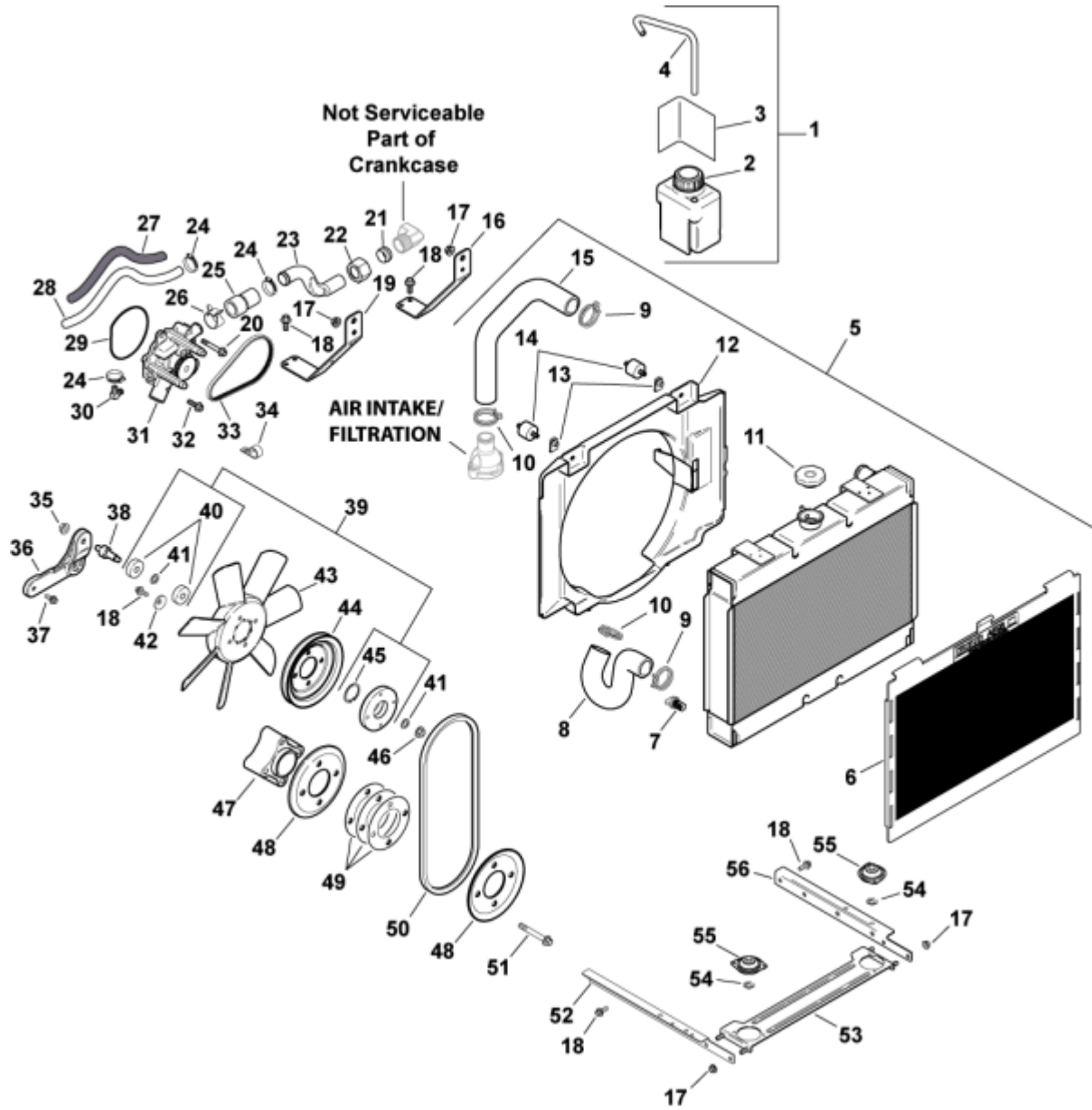

Cooling System

Ref #	Part	Description	Qty
1	66 065 02-S	KIT, OVERFLOW BOTTLE (INCLUDES 2-4)	1
2	66 173 08-S	CAP, OVERFLOW	1
3	66 113 03-S	DECAL, COOLANT LEVEL	1
4	66 326 08-S	HOSE, OVERFLOW	1
5	66 398 08-S	KIT, RADIATOR w/HOSES (INCLUDES 4, 6-15 & 66 326 30-S)	1
6	66 162 01-S	SCREEN, GRASS (FLAT)	1
7	66 139 04-S	PLUG, DRAIN	1
8	66 326 07-S	HOSE, RADIATOR TO WATER PUMP	1
9	66 237 20-S	CLAMP, CONSTANT TENSION BAND	2
10	66 237 18-S	CLAMP, THERMOSTAT HSG OUTLET	2
11	66 173 01-S	CAP, RADIATOR	1
12	66 424 01-S	SHROUD, FAN	1
13	66 154 02-S	U CLIP	2
14	66 366 01-S	MOUNT, ISOLATION	2
15	66 326 06-S	HOSE, THERMOSTAT TO RADIATOR	1
16	66 126 37-S	BRACKET, UPPER RADIATOR #1	1
17	M-641060-S	NUT, FLG M6X1.0	6
18	M-651016-S	SCREW, FLG M6X1.0X16	12
19	66 126 38-S	BRACKET, UPPER RADIATOR #2	1
20	M-651040-S	SCREW, FLG M6X1.0X40	1
21	66 431 03-S	SLEEVE	1
22	66 100 01-S	NUT	1
23	66 123 03-S	TUBE, CROSSOVER	1
24	25 237 12-S	CLAMP, HOSE	3
25	66 123 01-S	TUBE, CROSSOVER	1
26	66 237 07-S	CLAMP	1
27	24 431 02-S	SLEEVE, INSULATING 14"	1
28	66 326 35-S	HOSE, BY-PASS 13"	1
29	66 153 01-S	O-RING	1
30	45 155 01-S	CONNECTOR	1
31	66 393 01-S	PUMP, WATER	1
32	M-651020-S	SCREW, FLG M6x1.0x20	5
33	66 203 01-S	BELT, WATER PUMP	1
34	235173-S	CLIP, CABLE	1
35	M-841080-S	NUT, FLG M8X1.25	1
36	66 126 72-S	BRACKET, FAN	1
37	M-851016-S	SCREW, FLG 8X1.25X16	2
38	66 144 02-S	SHAFT, FAN	1
39	66 230 02-S	KIT, BEARING CARRIER (INCLUDES 40, 41 [QTY 1], 45)	1
40	66 030 01-S	BEARING, BALL	2
41	X-25-28-S	WASHER, FLAT 13/32"	2
42	52 468 11-S	WASHER, SPRING 1/4"	4
43	66 157 02-S	FAN, AXIAL PULLER	1
44	66 093 03-S	PULLEY, FAN	1
45	66 141 01-S	RING, RETAINER-INTL O.D. 30MM	1
46	M-841060-S	NUT, HEX FLANGE	1
47	66 029 02-S	ADAPTER, CRANKSHAFT PULLEY	1
48	66 093 04-S	PULLEY, CRANKSHAFT	2
49	66 422 14-S	SHIM, CRANKSHAFT PULLEY	3
50	66 203 02-S	BELT, FAN	1
51	M-851060-S	SCREW, FLG M8X1.25X60	4
52	66 126 65-S	BRCKT KIT, LWR RADIATOR #2 (INCLUDES 66 755 14-S)	1
53	66 126 39-S	BRACKET, RADIATOR CROSS	1
54	25 018 02-S	RETAINER, E-CLIP	2
55	66 366 02-S	MOUNT, PLATEFORM	2
56	66 126 64-S	BRCKT KIT, LWR RADIATOR #1 (INCLUDES 66 755 14-S)	1
	25 454 03-S	TIE, WIRE NOT ILLUSTRATED	4
	66 326 30-S	HOSE, OVERFLOW NOT ILLUSTRATED	1

66 755 14-S	KIT, RAD BRCKT MTG HARDWARE NOT ILLUSTRATED (INCLUDES 13, 17 [QTY 4], 18 [QTY 2], M-670016-S, M-670045-S, X-25-52-S)	1
M-670016-S	SCREW, THRD FRM M6X1.0X16 NOT ILLUSTRATED	4
M-670045-S	SCREW, THRD FRM M6X1.0X45 NOT ILLUSTRATED	2
X-25-52-S	WASHER, FLAT 1/4" NOT ILLUSTRATED	2

Crankcase

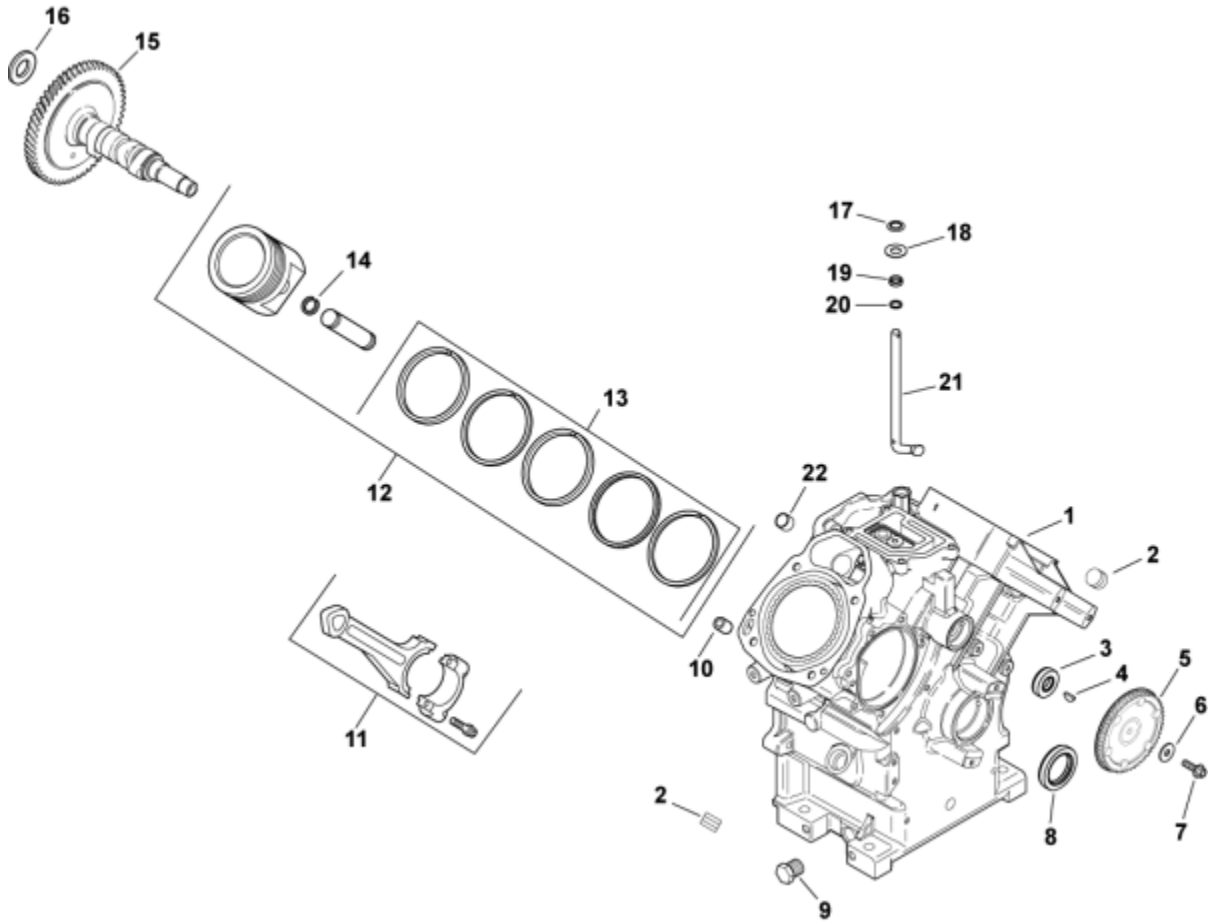

Crankcase

Ref #	Part	Description	Qty
1		CRANKCASE (USE SHORT BLOCK)	1
2	25 139 62-S	PLUG, PIPE CTSK 3/8"	2
3	66 032 07-S	SEAL, CAMSHAFT	1
4	X-42-2-S	KEY, 3/32" X 3/8"	1
5	66 093 01-S	SPROCKET, CAMSHAFT	1
6	X-25-52-S	WASHER, FLAT 1/4"	1
7	M-651020-S	SCREW, FLG M6x1.0x20	1
8	24 032 01-S	SEAL, OIL	1
9	52 139 02-S	PLUG, DRAIN	2
10	24 380 16-S	PIN, LOCATING	2
11	24 067 16-S	CONNECTING ROD (STD)	2
	24 067 14-S	CONNECTING ROD (.25) - USE 24 067 17-S	2
12	24 874 09-S	KIT, PISTON W/RING (STD) - USE 24 874 34-S (INCLUDES 13, 14)	2
	24 874 15-S	KIT, PISTON W/RING (.08)	2
	24 874 10-S	KIT, PISTON W/RING (.25)	2
	24 874 11-S	KIT, PISTON W/RING (.50)	2
13	24 108 08-S	RING, SET PISTON (STD & .08)	2
	24 108 09-S	RING, SET (.25)	2
	24 108 10-S	RING, SET (.50)	2
14	24 018 01-S	RETAINER, PISTON PIN	4
15	66 012 01-S	KIT, CAMSHAFT (INCLUDES 25 357 14-S)	1
16	12 422 07-S	SHIM, CAMSHAFT (WHITE .028")	A.R.
	12 422 08-S	SHIM, CAMSHAFT (BLUE .03")	A.R.
	12 422 09-S	SHIM, CAMSHAFT (RED .032")	A.R.
	12 422 10-S	SHIM, CAMSHAFT (YELLOW .034")	A.R.
	12 422 11-S	SHIM, CAMSHAFT (GREEN .036")	A.R.
	12 422 12-S	SHIM, CAMSHAFT (GRAY .038")	A.R.
	12 422 13-S	SHIM, CAMSHAFT (BLACK .04")	A.R.
17	24 018 09-S	RETAINER, RING	1
18	M-931010-S	WASHER, FLAT 9 MM	1
19	28 032 09-S	SEAL, GOVERNOR CROSS SHAFT	1
20	24 468 15-S	WASHER, FLAT 11/32"	1
21	24 144 38-S	SHAFT, GOVERNOR CROSS	1
22	52 139 09-S	PLUG, CUP	1
	25 357 14-S	LUBRICANT, CAMSHAFT NOT ILLUSTRATED	1

Crankshaft

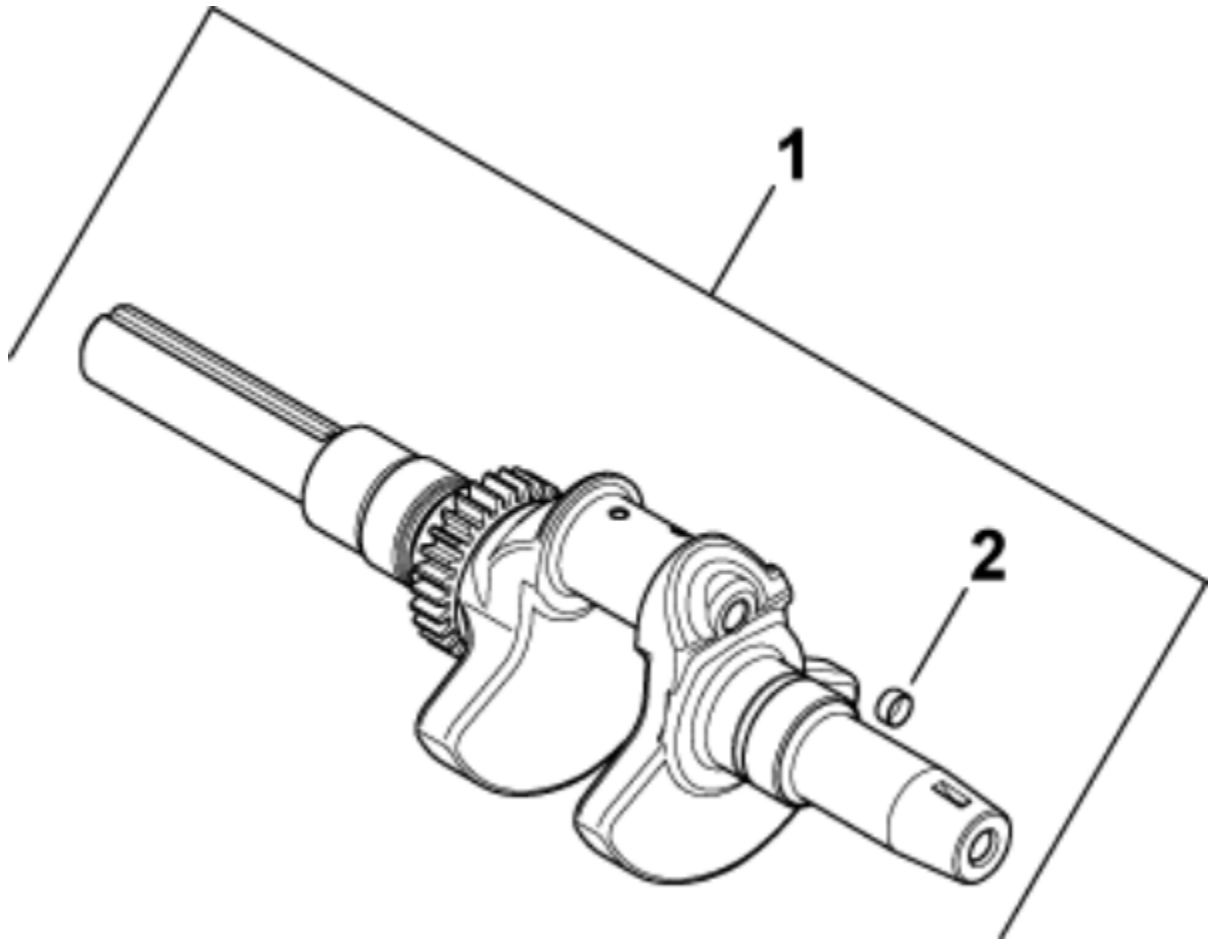

Crankshaft

Ref #	Part	Description	Qty
1	66 014 34-S	CRANKSHAFT ASSEMBLY (includes 2)	1
2	52 139 09-S	PLUG, CUP	1

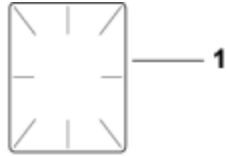

Artwork is representative.
Actual labels may differ depending on model and specification number.

Decals

Ref #	Part	Description	Qty
1	25 113 39-S	DECAL, CLEAR LAMINATE	1
2	66 113 15-S	DECAL, 26HP	1
3	25 113 05-S	DECAL, OIL SENTRY	1
4	66 113 04-S	DECAL, ROTATING FAN WARNING	1

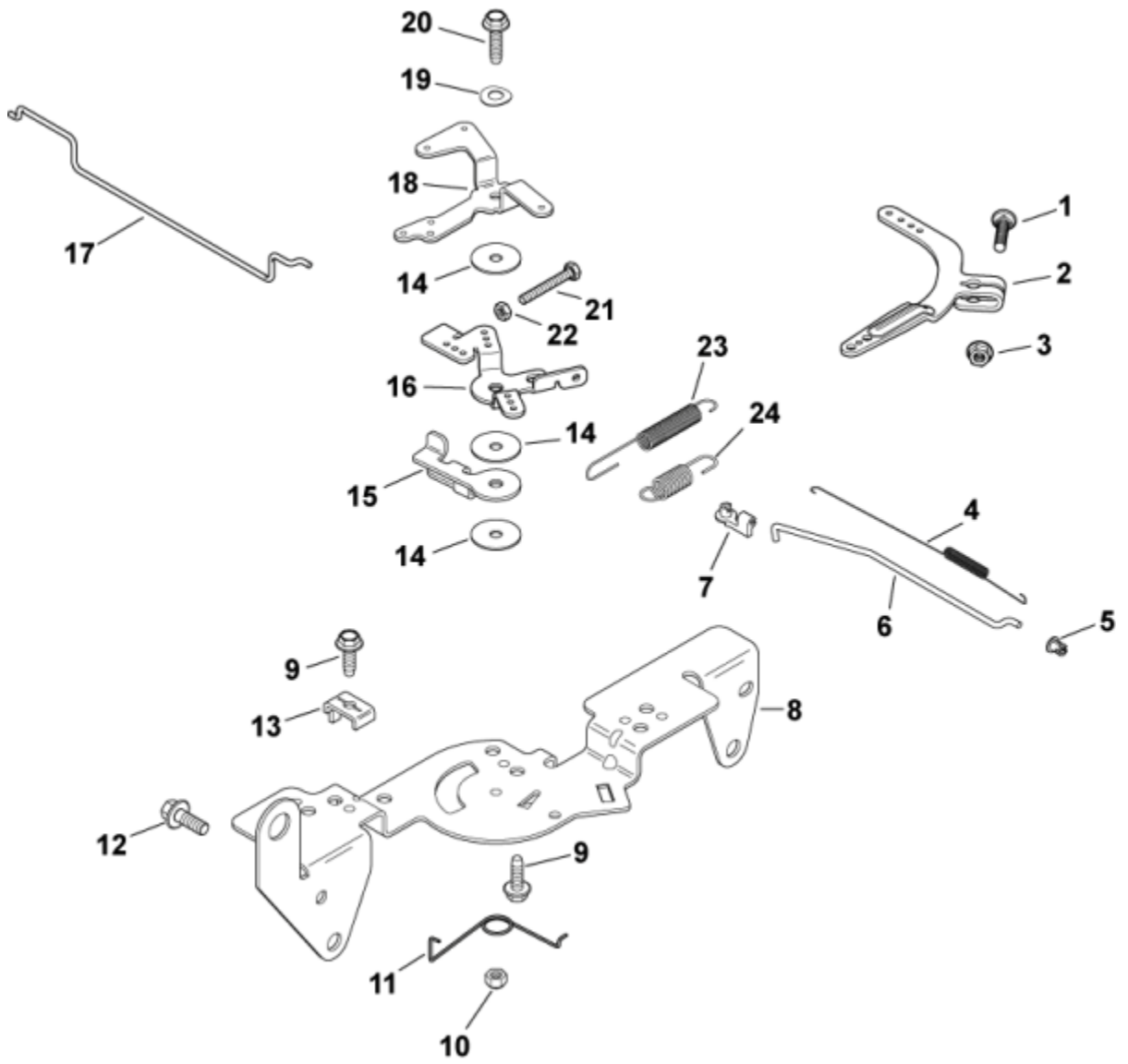

Engine Controls

Ref #	Part	Description	Qty
1	24 211 03-S	BOLT, RD HD SQ NECK M6X1.0X25	1
2	24 090 33-S	LEVER, GOVERNOR	1
3	M-641060-S	NUT, FLG M6X1.0	1
4	24 089 01-S	SPRING, LINKAGE	1
5	25 158 08-S	BUSHING, LINKAGE RETAINING	1
6	24 079 01-S	LINKAGE, THROTTLE	1
7	25 158 11-S	BUSHING, THROTTLE LINKAGE	1
8	24 126 56-S	BRACKET, CONTROL	1
9	M-545016-S	SCREW, FLG THD FRM M5X0.8X16	3
10	M-547050-S	NUT, LOCK M5X0.8	1
11	24 089 03-S	SPRING, CHOKE RETURN	1
12	M-651016-S	SCREW, FLG M6X1.0X16	4
13	12 237 01-S	CLAMP, CABLE	2
14	24 468 01-S	WASHER, FLAT 5.5 MM	3
15	24 090 07-S	LEVER, THROTTLE ACTUATOR	1
16	24 090 03-S	LEVER, THROTTLE CONTROL	1
17	24 079 21-S	LINKAGE, CHOKE	1
18	24 090 05-S	LEVER, CHOKE	1
19	41 468 03-S	WASHER, SPRING 1/4"	1
20	M-545020-S	SCREW, FLG THD FRM M5X0.8X20	1
21	M-401030-S	SCREW, CAP M4X0.7X30	1
22	M-446030-S	NUT, M4X0.7	1
23	24 089 51-S	SPRING, THROTTLE LIMITER	1
24	24 089 44-S	SPRING, GOVERNOR	1

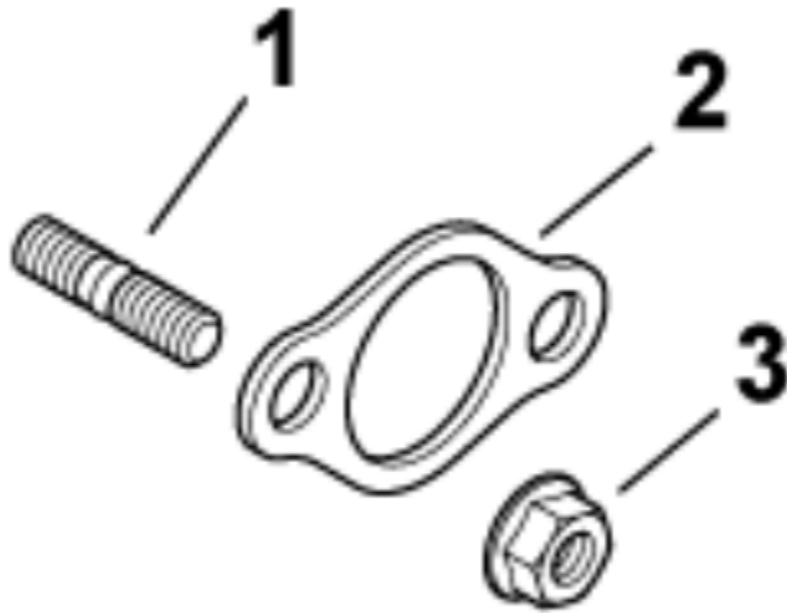

Exhaust

Ref #	Part	Description	Qty
1	25 072 04-S	STUD, M8X1.25X33	4
2	24 041 49-S	GASKET, EXHAUST	2
3	M-841080-S	NUT, FLG M8X1.25	4

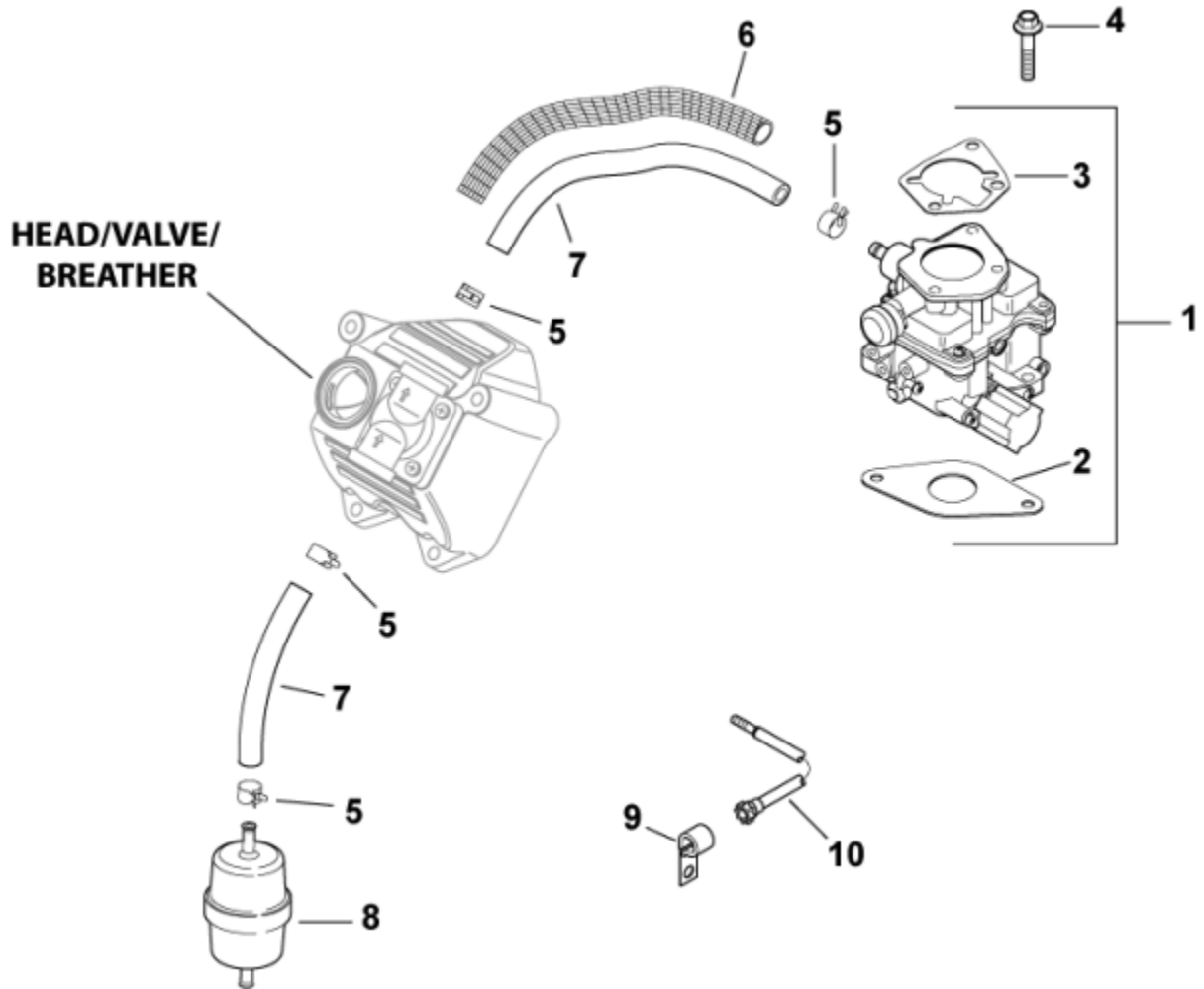

Fuel System

Ref #	Part	Description	Qty
1	24 853 59-S	CARBURETOR W/GASKETS (INCLUDES 2, 3)	1
2	24 041 17-S	GASKET, CARBURETOR	1
3	24 041 06-S	GASKET, AIR CLEANER BASE	1
4	M-651030-S	SCREW, FLG M6X1.0X30	2
5	25 237 14-S	CLAMP, SPRING HOSE 1/2"	4
6	24 431 02-S	SLEEVE, INSULATING 14"	1
7	25 111 34-S	LINE, FUEL (24"-CUT TO LENGTH)	2
8	24 050 10-S	FILTER, FUEL	1
9	235173-S	CLIP, CABLE	1
10	66 159 01-S	CABLE, CARBURETOR ADJUSTER	1
	24 755 125-S	KIT, HIGH ALTITUDE NOT ILLUSTRATED	1
	24 757 01-S	KIT, REPAIR SOLENOID NOT ILLUSTRATED	1
	24 757 02-S	KIT, REPAIR FLOAT NOT ILLUSTRATED	1
	24 757 03-S	KIT, REPAIR CARBURETOR NOT ILLUSTRATED	1
	24 757 07-S	KIT, REPAIR CHOKE NOT ILLUSTRATED	1

Gasket Set

Ref #	Part	Description	Qty
	66 755 01-S	Gasket Set	1
	220534-S	WASHER, FLAT 5/16"	8
	12 153 02-S	O-RING, UPPER OIL FILL TUBE	1
	12 153 07-S	O-RING	1
	24 032 01-S	SEAL, OIL	1
	24 041 14-S	GASKET, AIR CLEANER BASE	1
	24 041 17-S	GASKET, CARBURETOR	1
	24 041 49-S	GASKET, EXHAUST	2
	24 041 51-S	GASKET, BREATHER	1
	24 100 10-S	NUT, FLG M8X1.25	8
	24 153 08-S	O-RING	1
	28 032 09-S	SEAL, GOVERNOR CROSS SHAFT	1
	52 032 08-S	SEAL, OIL (PTO END)	1
	66 032 05-S	SEAL, VALVE STEM	4
	66 032 07-S	SEAL, CAMSHAFT	1
	66 041 01-S	GASKET, THERMOSTAT	1
	66 841 02-S	KIT, CYLINDER HEAD GASKET	2
	66 041 05-S	GASKET, INTAKE MANIFOLD	2
	66 041 09-S	GASKET, VALVE COVER	2
	66 153 01-S	O-RING	1
	24 041 51-S	GASKET, BREATHER	1

Head/Valve/Breather

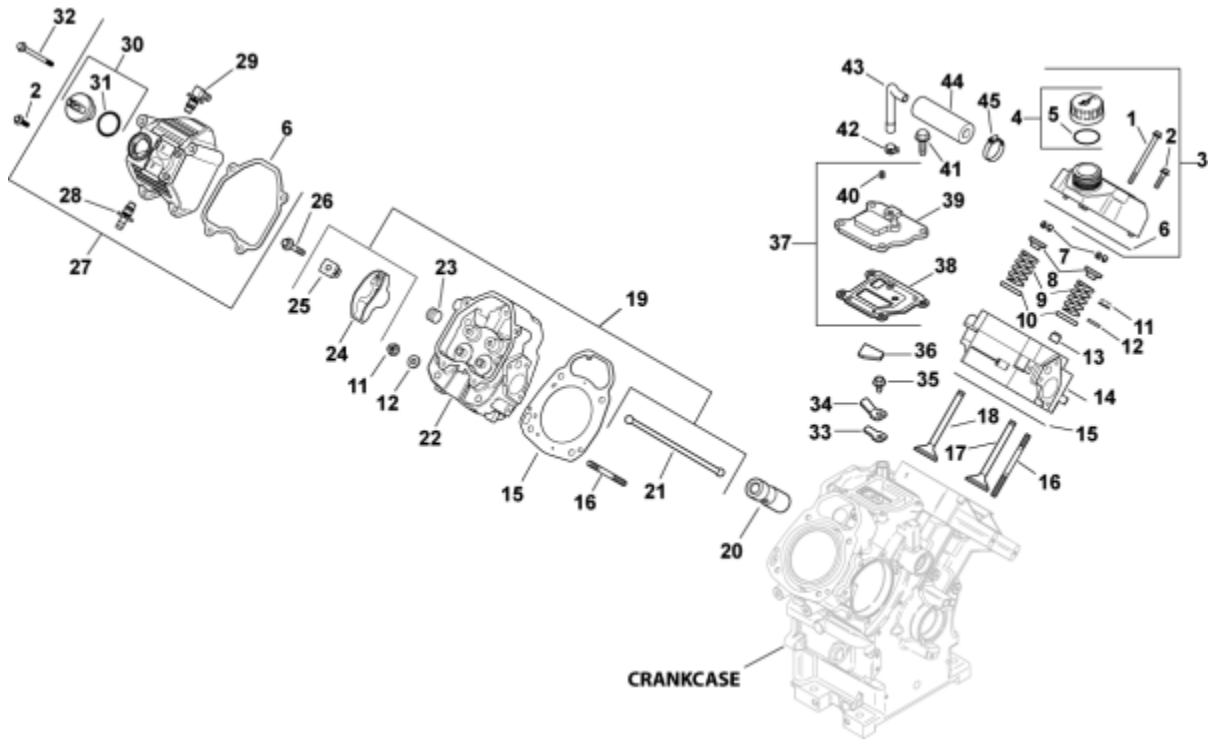

Head/Valve/Breather

Ref #	Part	Description	Qty
1	25 086 84-S	SCREW, FLG M6X1.0X55	2
2	M-651025-S	SCREW, FLG M6X1.0X25 - USE 25 086 124-S	4
3	66 755 10-S	KIT,LH OIL FILL VALVE COVER (INCLUDES 1, 2, 4, 5, 6 [QTY 1])	1
4	24 755 46-S	KIT, OIL FILL CAP (YELLOW) (INCLUDES 5)	1
5	25 153 02-S	O-RING	1
6	66 041 09-S	GASKET, VALVE COVER	2
7	12 755 03-S	KIT, RETAINER	4
8	12 173 01-S	CAP, VALVE SPRING	4
9	24 089 02-S	SPRING, VALVE	4
10	66 018 02-S	RETAINER	4
11	24 100 10-S	NUT, FLG M8X1.25	8
12	220534-S	WASHER, FLAT 5/16"	8
13	66 032 05-S	SEAL, VALVE STEM (AFTER S/N 3421600001)	4
	66 032 05-S	SEAL, VALVE STEM (BEFORE S/N 3421600011)	2
14	66 318 01-S	KIT,CYLINDER HEAD #1	1
15	66 841 02-S	KIT, CYLINDER HEAD GASKET (INCLUDES 11, 12, 24 041 49-S & 66 041 05-S)	2
16	66 072 03-S	STUD	8
17	24 017 01-S	VALVE, INTAKE (STD)	2
	24 017 02-S	VALVE, INTAKE (.25)	2
18	24 016 01-S	VALVE, EXHAUST (STD)	2
	24 016 02-S	VALVE, EXHAUST (.25)	2
19	24 755 66-S	KIT, VALVE TRAIN (INCLUDES 21, 24, 25)	1
20	25 351 04-S	KIT, HYDRAULIC VALVE LIFTER (INCLUDES 25 357 14-S)	4
21	24 411 05-S	ROD, PUSH	4
22	66 318 02-S	KIT,CYLINDER HEAD #2	1
23	66 139 01-S	PLUG, PIPE	2
24	25 186 01-S	ARM, ROCKER	4
25	24 599 02-S	PIVOT, ROCKER ARM	4
26	66 086 07-S	SCREW, ROCKER ARM PIVOT	4
27	66 559 02-S	KIT, FUEL PUMP/ROCKER COVER (INCLUDES 6 [QTY 1], 28-31, 45 [QTY 2], 25 141 06-S)	1
28	25 294 09-S	KIT, STRAIGHT FITTING	1
29	25 294 11-S	KIT, 90° FITTING	2
30	24 227 02-S	CAP ASSY, OIL FILL (YELLOW) (INCLUDES 31)	1
31	24 153 09-S	O-RING	1
32	M-651080-S	SCREW, FLG M6X1.0X80	2
33	24 402 03-S	REED, BREATHER	1
34	66 018 04-S	RETAINER, REED	1
35	M-545010-S	SCREW, FLG THD FRM M5X0.8X10	1
36	24 050 01-S	FILTER, BREATHER	1
37	24 033 01-S	KIT, BREATHER ASSEMBLY (INCLUDES 38-40)	1
38	24 041 51-S	GASKET, BREATHER	1
39	24 096 86-S	COVER, BREATHER	1
40	25 139 60-S	PLUG, CTSK PIPE 1/8"	1
41	M-645020-S	SCREW, FLG THD FRM M6X1.0X20	4
42	25 237 08-S	CLAMP, SPRING HOSE	1
43	24 326 77-S	HOSE, BREATHER - USE 24 326 96-S	1
44	24 168 01-S	INSULATOR, BREATHER HOSE	1
45	25 237 14-S	CLAMP, SPRING HOSE 1/2"	3
	24 041 49-S	GASKET, EXHAUST NOT ILLUSTRATED	1
	66 041 05-S	GASKET, INTAKE MANIFOLD NOT ILLUSTRATED	1
	25 357 14-S	LUBRICANT, CAMSHAFT NOT ILLUSTRATED	1
	25 141 06-S	TOOL, INSTALLATION (SNAP RING) NOT ILLUSTRATED	1

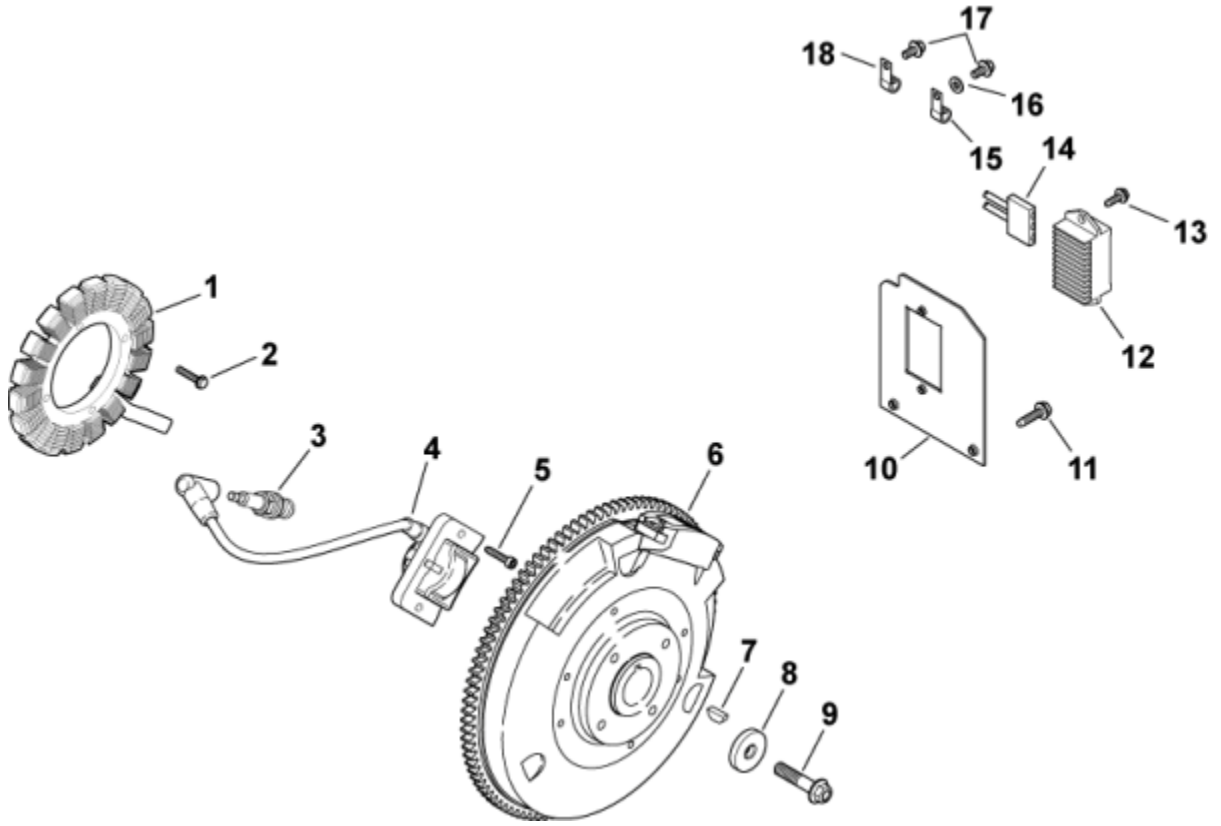

Ignition/Electrical

Ref #	Part	Description	Qty
1	28 085 02-S	KIT, 25 AMP STATOR ASSY. (INCLUDES 2, 14, 25 155 06-S, 25 452 01-S, 25 452 06-S)	1
2	25 086 29-S	SCREW, WSH HD TAP #10-24X1"	4
3	66 132 01-S	SPARK PLUG	2
4	28 584 01-S	MODULE, IGNITION	2
5	M-561025-S	SCREW, SKT THD FRM M5X0.8X25	4
6	66 025 02-S	FLYWHEEL ASSEMBLY	1
7	X-42-15-S	KEY, 3/16" X 5/8"	1
8	12 468 03-S	WASHER, FLAT 13/32"	1
9	12 086 14-S	SCREW, FLG M10X1.5X45	1
10	66 126 50-S	BRACKET, REGULATOR MOUNTING	1
11	M-645025-S	SCREW, FLG THD FRM M6X1.0X25	2
12	25 403 05-S	REGULATOR/RECTIFIER	1
13	M-561016-S	SCREW, FLG THD FRM M5X0.8X16	2
14	236602-S	CONNECTOR (3 CONTACT)	1
15	235173-S	CLIP, CABLE	1
16	X-25-63-S	WASHER, FLAT 1/4"	1
17	M-651012-S	SCREW, FLG M6X1.0X12	4
18	47 154 01-S	CLIP, CABLE	1
	X-22-5-S	WASHER NOT ILLUSTRATED	1
	25 155 06-S	CONNECTOR NOT ILLUSTRATED	2
	25 452 01-S	TERMINAL NOT ILLUSTRATED	3
	25 452 06-S	TERMINAL NOT ILLUSTRATED	2
	24 518 12-S	LEAD NOT ILLUSTRATED	1
	12 454 03-S	TIE, CABLE NOT ILLUSTRATED	2
	25 454 04-S	TIE NOT ILLUSTRATED	1
	66 518 01-S	LEAD NOT ILLUSTRATED	1
	66 176 20-S	HARNESS, WIRING NOT ILLUSTRATED	1

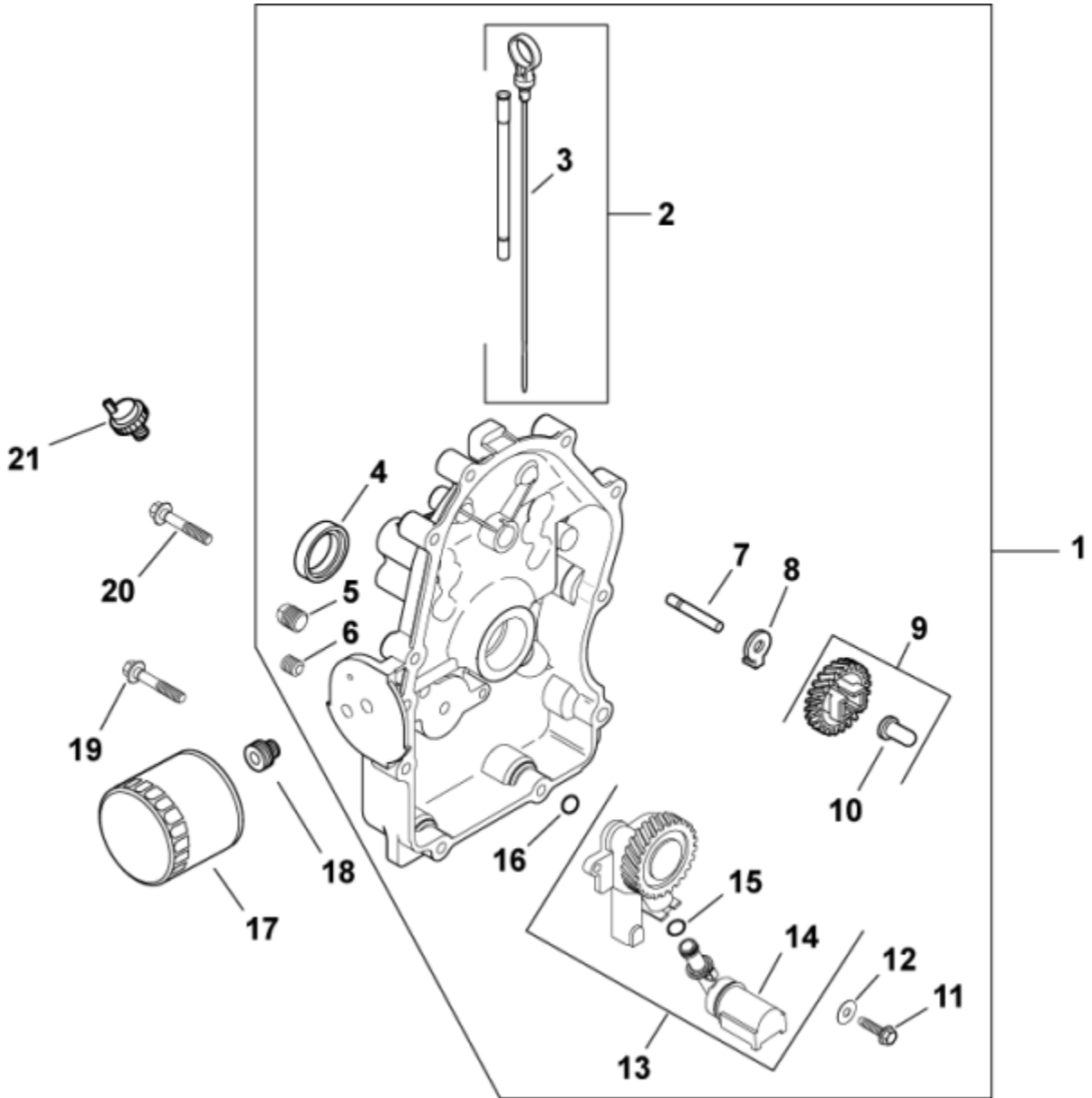

Oil Pan/Lubrication

Ref #	Part	Description	Qty
1	66 009 10-S	CLOSURE PLATE ASSEMBLY (includes 2-16)	1
2	24 755 121-S	KIT, DIPSTICK/DIPSTICK TUBES (includes 3)	1
3	24 038 10-S	DIPSTICK	1
4	52 032 08-S	SEAL, OIL (PTO END)	1
5	52 139 02-S	PLUG, DRAIN	1
6	25 139 60-S	PLUG, CTSK PIPE 1/8"	2
7	12 144 02-S	SHAFT, GOVERNOR GEAR	1
8	24 448 02-S	TAB, LOCKING	1
9	24 043 12-S	KIT, GOVERNOR GEAR W/PIN (includes 10)	1
10	12 380 01-S	PIN, GOVERNOR REGULATING	1
11	M-645025-S	SCREW, FLG THD FRM M6X1.0X25	2
12	M-631005-S	WASHER, FLAT 6 MM	2
13	24 393 51-S	KIT, OIL PUMP ASSEMBLY (includes 14,15)	1
14	24 381 04-S	PICK-UP, OIL	1
15	24 153 01-S	O-RING, OIL PICK-UP	1
16	24 153 08-S	O-RING	1
17	12 050 01-S	FILTER, OIL	1
18	24 136 01-S	NIPPLE, OIL FILTER	1
19	24 086 17-S	SCREW, FLG M8X1.25X45	1
20	24 086 16-S	SCREW, FLG M8X1.25X45	9
21	25 099 27-S	SWITCH, OIL PRESSURE	1

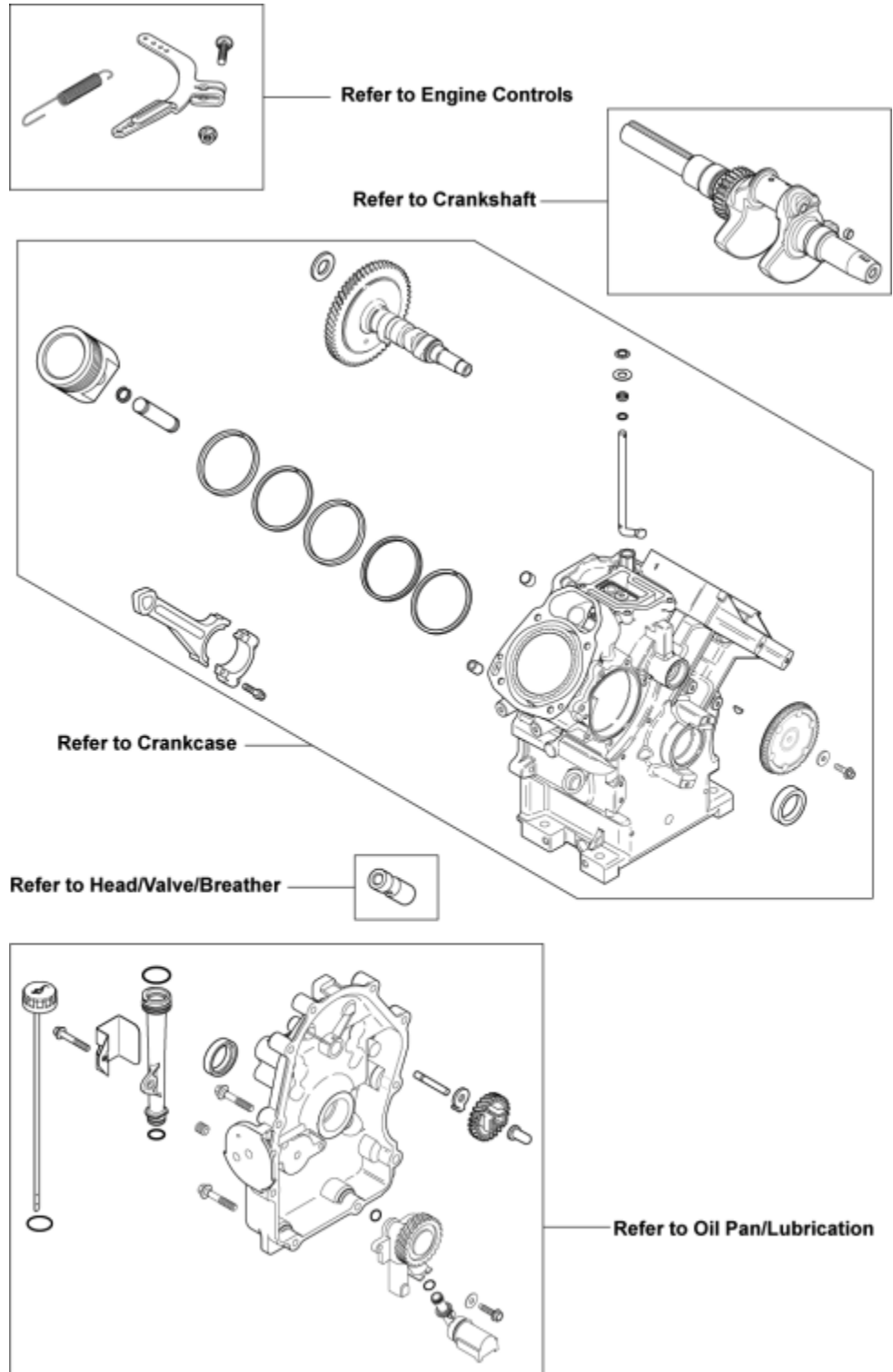

**Artwork is representative.
Actual piece parts will differ depending on model and specification number.**

Short Block w/gasket set

Ref #	Part	Description
	66 522 05	LH685S SHORT BLOCK (includes parts shown-artwork is representative - actual piece parts will differ depending on model and specific

Starting System

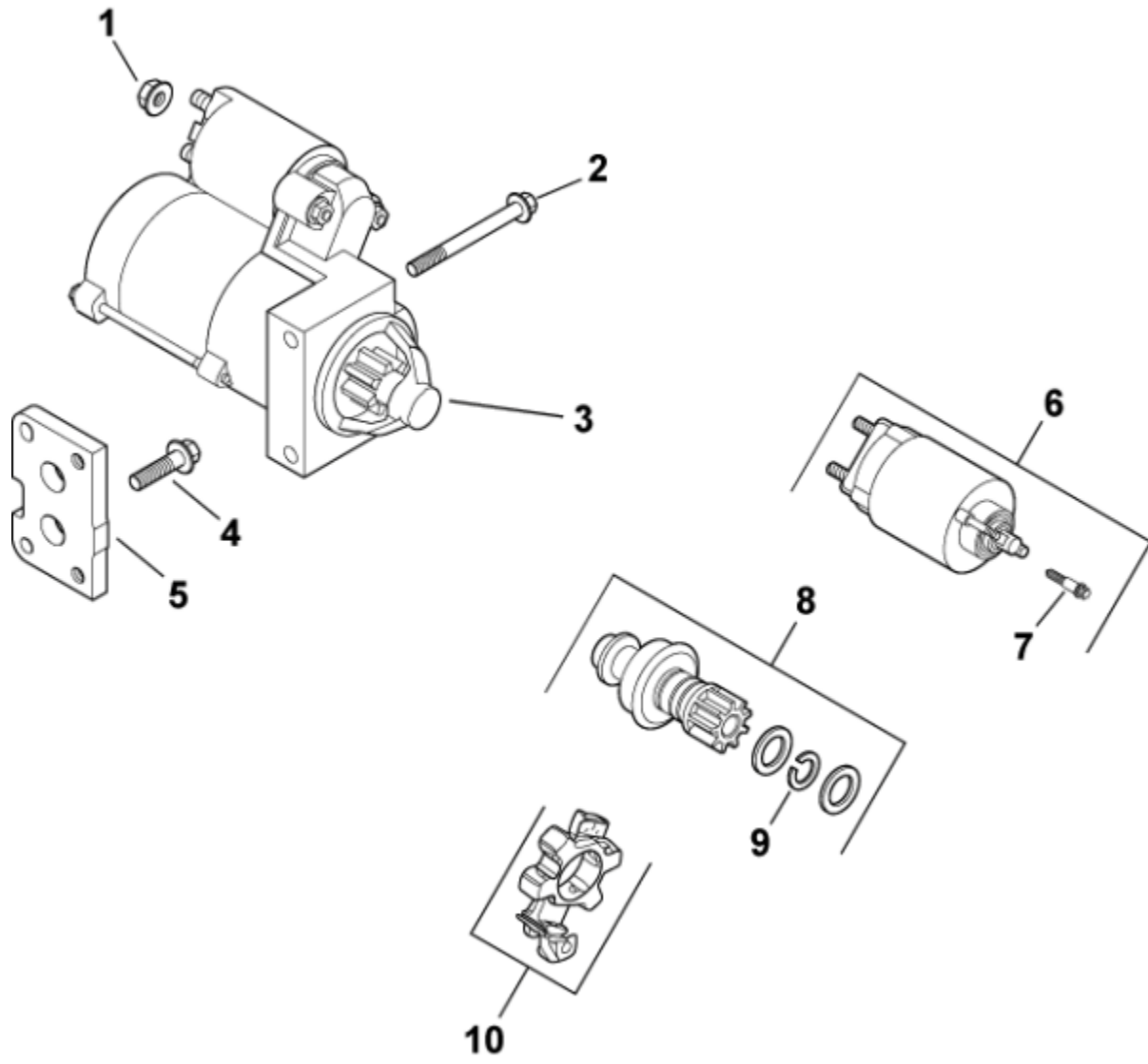

Starting System

Ref #	Part	Description	Qty
1	M-841080-S	NUT, FLG M8X1.25	1
2	M-839080-S	SCREW, FLG M8X1.25X80	2
3	25 098 09-S	STARTER ASSY, SOLENOID SHIFT (INCLUDES 6-10)	1
4	M-851030-S	SCREW, FLG M8X1.25X30	2
5	66 146 10-S	PLATE, STARTER	1
6	25 435 06-S	KIT, SOLENOID (INCLUDES 7)	1
7	25 086 113-S	SCREW, EXTERNAL TORX HEAD	3
8	25 755 33-S	KIT, STARTER PINION (INCLUDES 9)	1
9	25 141 05-S	RING	1
10	25 221 01-S	KIT, BRUSH HOLDER	1